

Lighting

By Eric Foo

Workshop Overview

— [Lighting

— [Types of Light

— [Lighting Equipment

— [Electricity and Safety

— [Hands on

Why Lighting

— [Can't shoot what you can't see

— [Adds interest, mood, drama

— [The 3 most important things in video are:

— Lighting, lighting, lighting

— Poorly lit video look unprofessional! Be excellent

Lighting

Lighting



Lighting



Lighting

Lighting

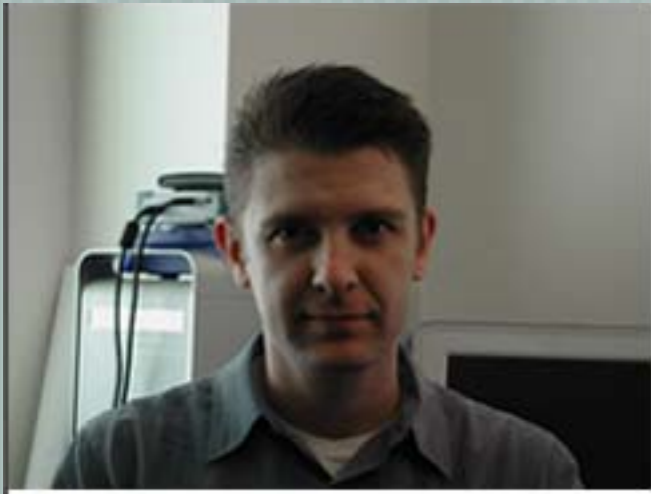

Lighting

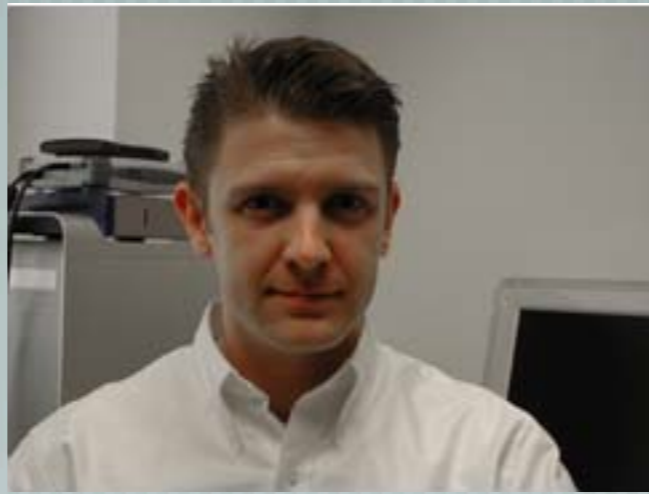
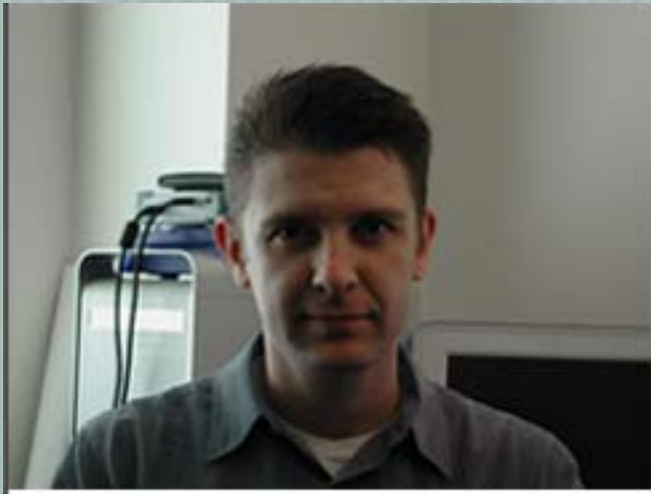

Lighting

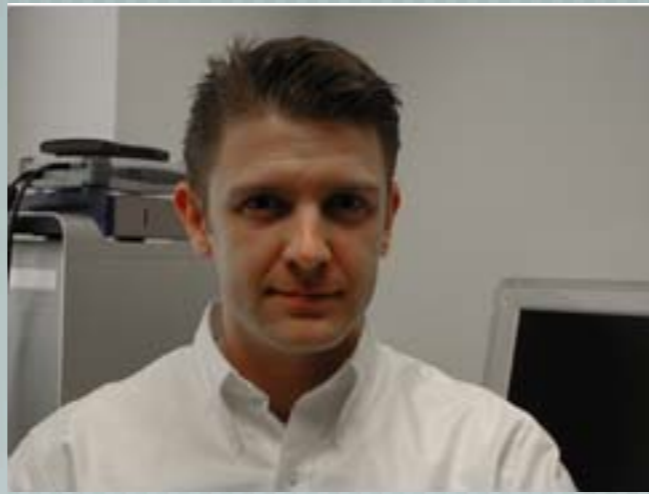
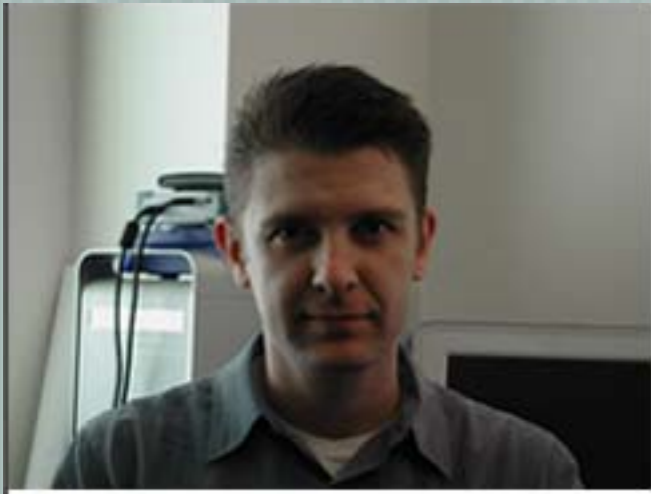

Lighting

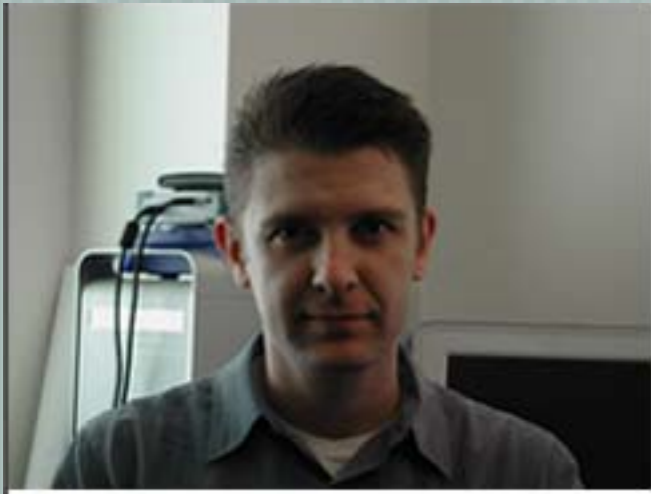

Lighting



Types of light

- [Many types of lighting instruments

- [Quality of light

- Hard-sharp, strong, hard shadows

- Soft-diffuse, soft edges on shadows

Tungsten

— [Most Common Lighting Instruments

— [Open Face-Red Heads/Lowels

— [Fresnels/Arri

Lights

Lights



Lights

Lights



Lights

Lights



Lights

Lights



Lights

Lights



Lights

Others

— [HMI

— [Fluorescent/Kino

— [LED

More Lights

More Lights



More Lights

More Lights



More Lights

More Lights



More Lights

Lighting Equipment

Lighting Equipment

— [Professional Lights

— [No Budget?

— DIY

DIY

— [Flood/Work Light-300W-500W

— [Clamp Light

— [Chinese Lantern with 200W Photoflood bulb

— [Reflectors/Car Shades/Shower Curtain

DIY Lights

DIY Lights



DIY Lights

DIY Lights



DIY Lights

DIY Lights



DIY Lights

3 Pin Plug

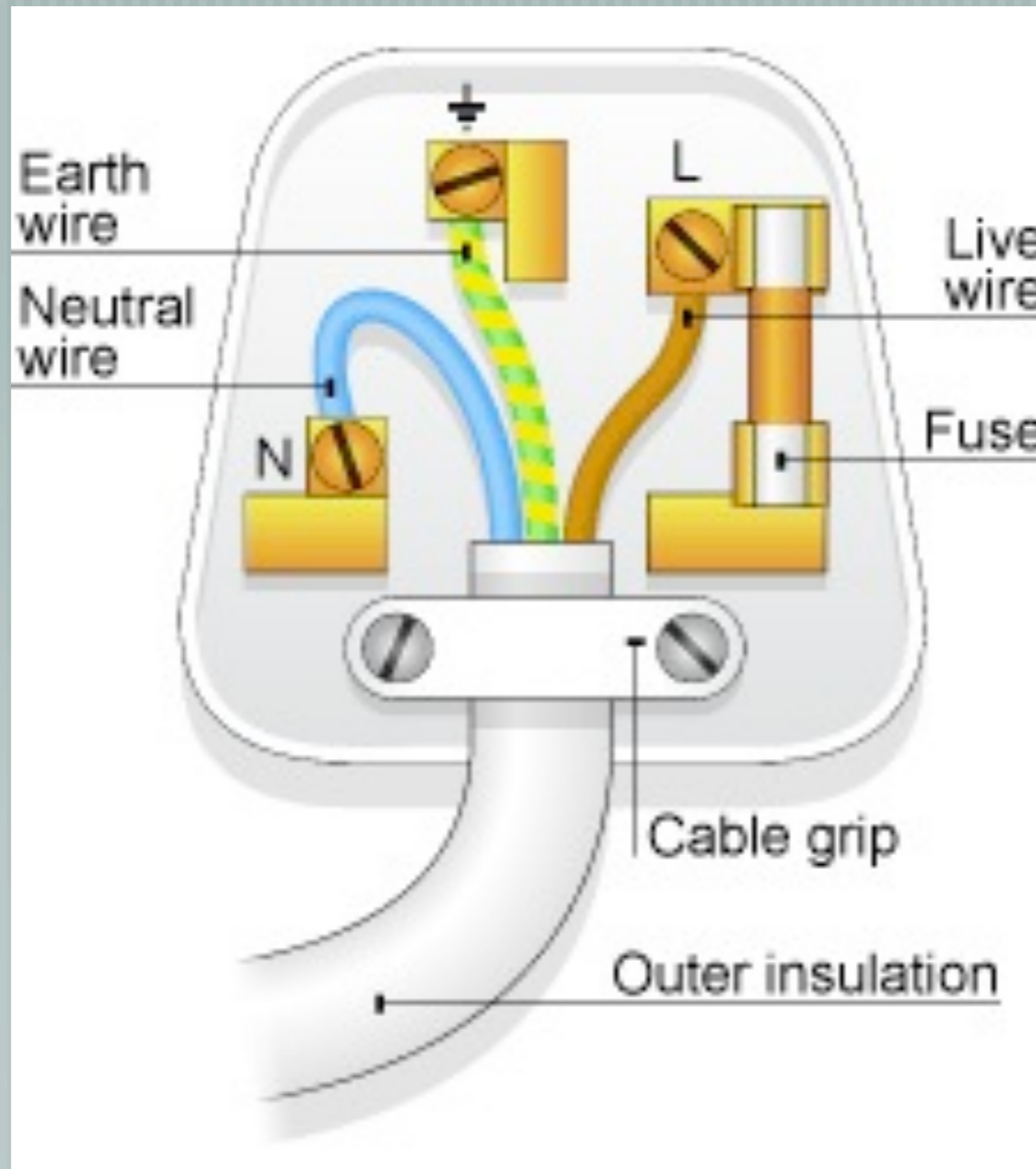

Safety!

- [Lighting is Dangerous!

- [Risks

- Fire

- Electrocutation

- Impact Injuries

Safety

— [Lights are HOT!-Gloves, Flammables, Fire Extinguisher

— [Check all plugs and connections

— [Make sure no short circuits

— [Sand bag/Cables out of the way

— [Setup Stands Properly

— [Keep Equipment Organised

3 Point Lighting

— [Key

— [Fill

— [Hair light (Kicker)

— [Why?

— Screen is 2D. 3 Point Lighting adds Depth

Key Light

— [Main Light

— [Strongest Light

— [1st Light you set up. Set Exposure

— [15° - 45° from camera

Key Light

Key Light

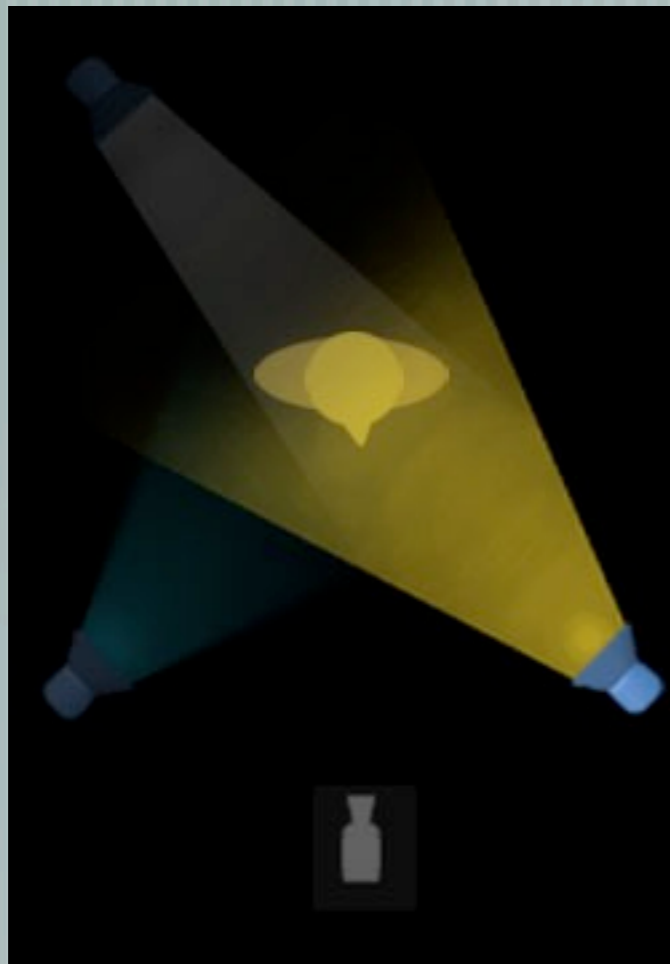

Key Light

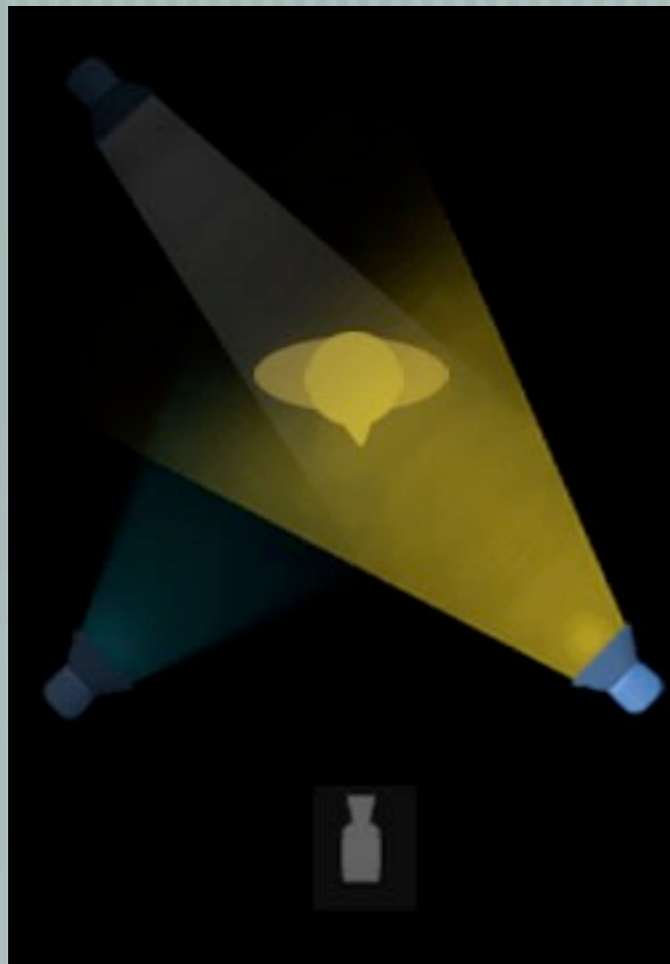

Key Light

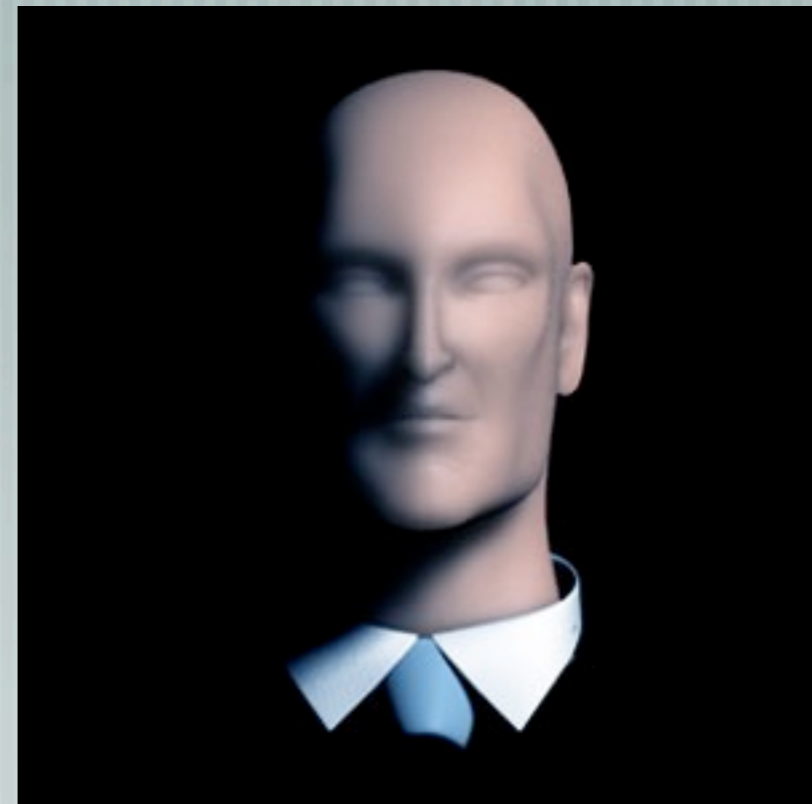
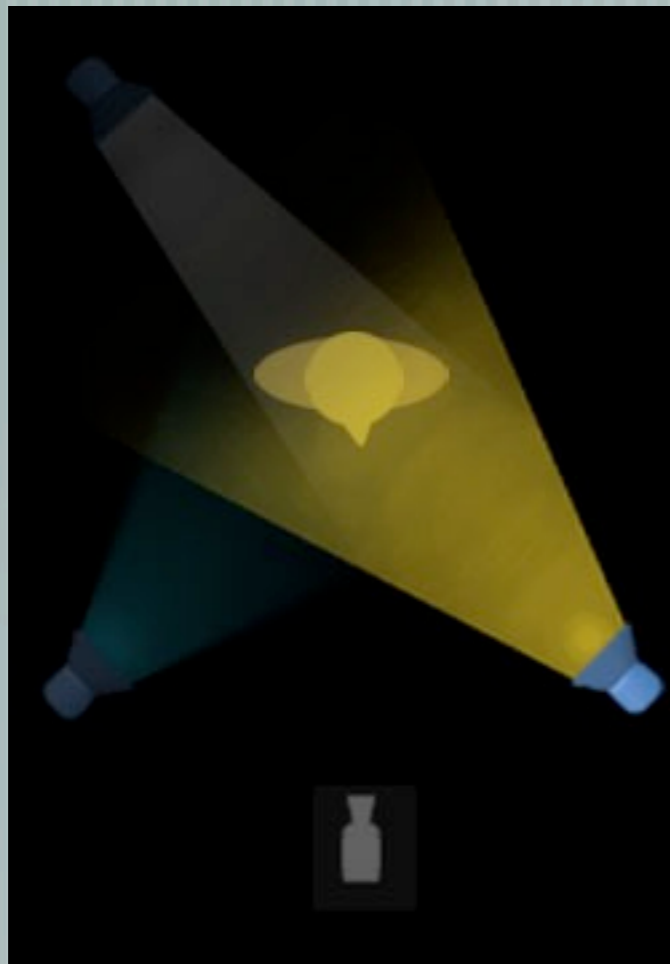
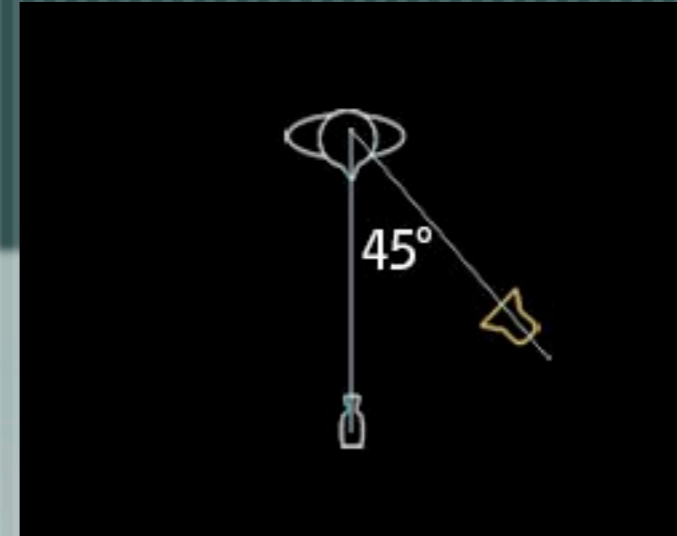

Fill Light

— [2nd Light to set up

— [Fills in shadows caused by Key

— [$\approx 50\%$ of Key

Fill Light

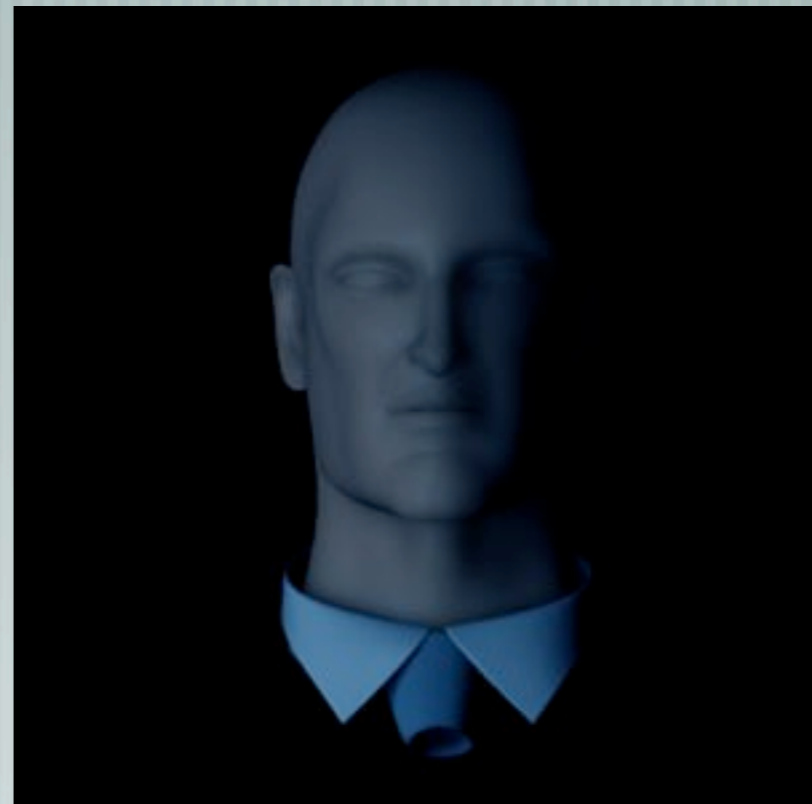
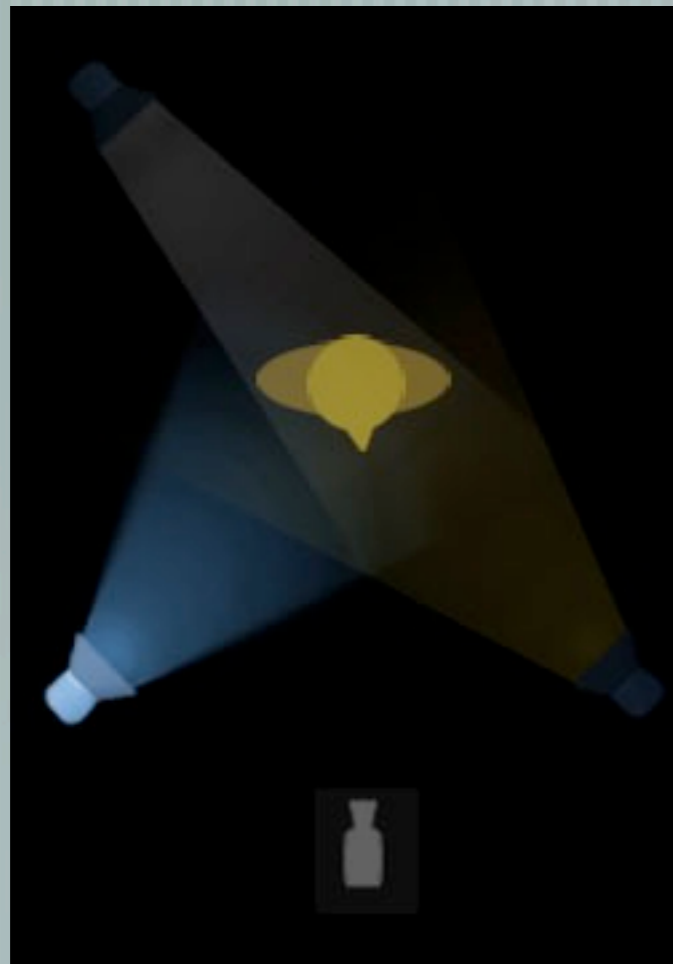

Fill Light

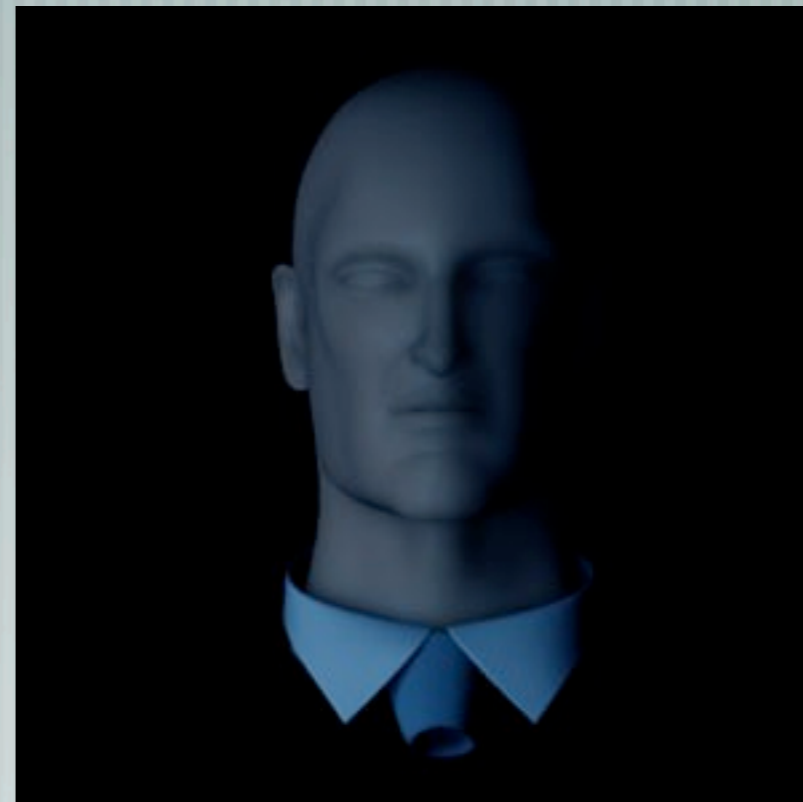
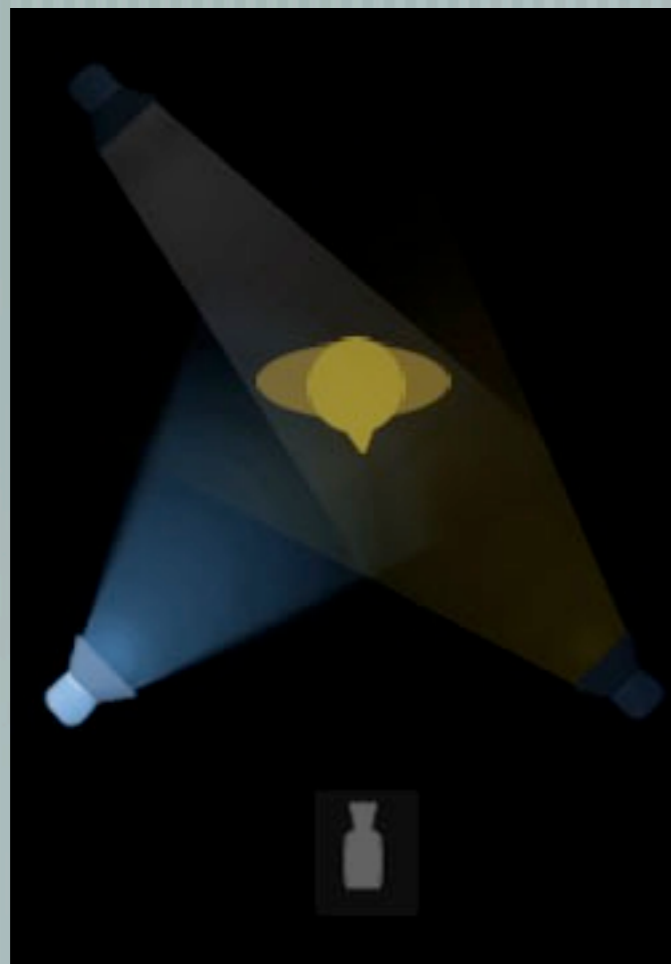

Hair Light/Kicker

— [Set up 3rd

— [Purpose is to make subject stand out from background

— [Adds to 3D look

— [Light head and shoulders, make hair 'glow'

— [Less than 50% of key

Hair Light/Kicker

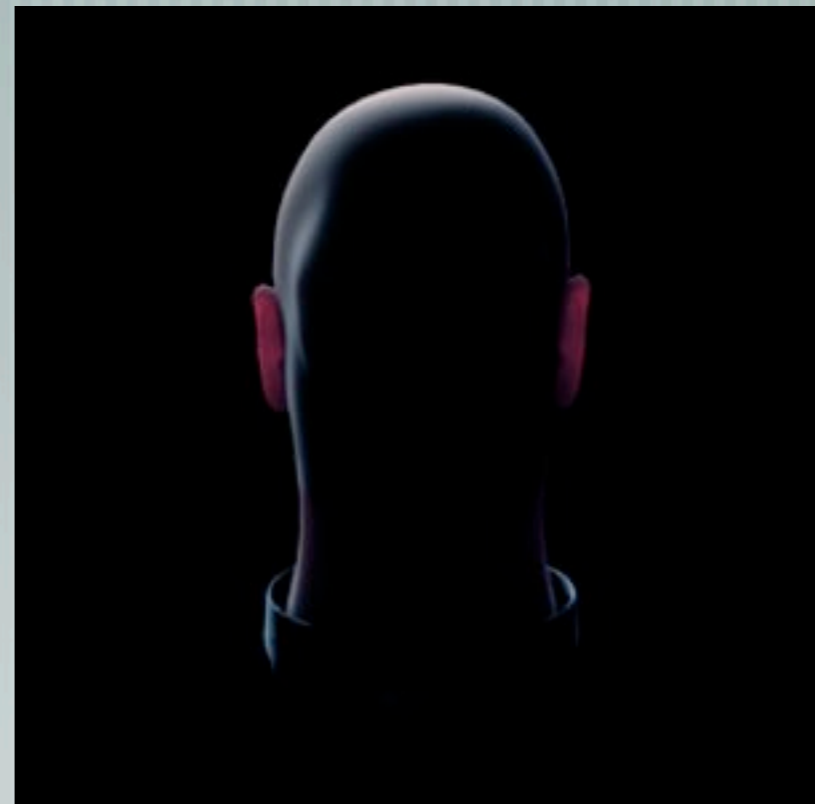
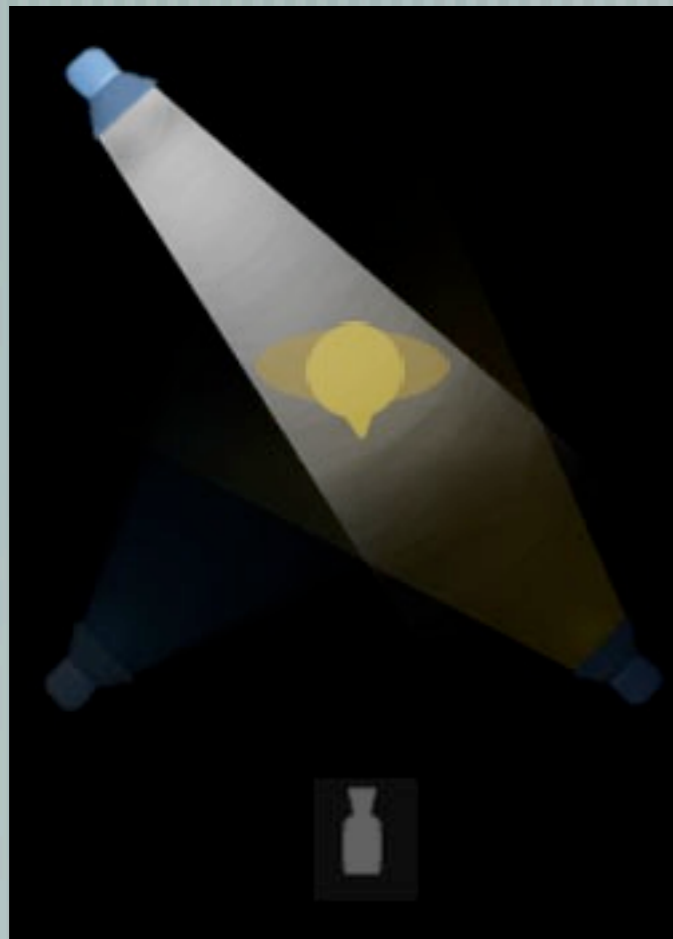

Hair Light/Kicker

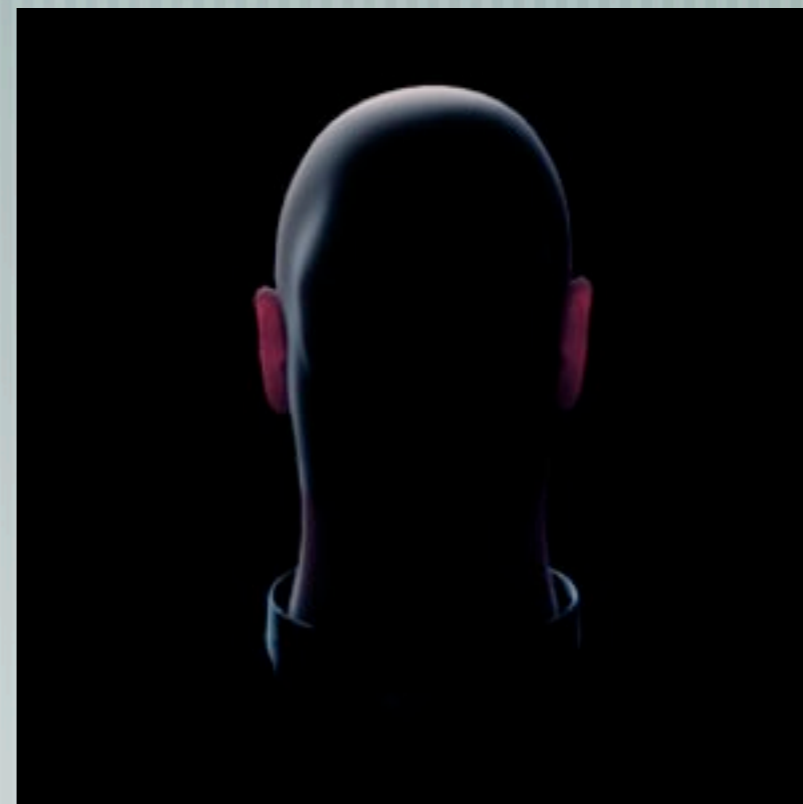
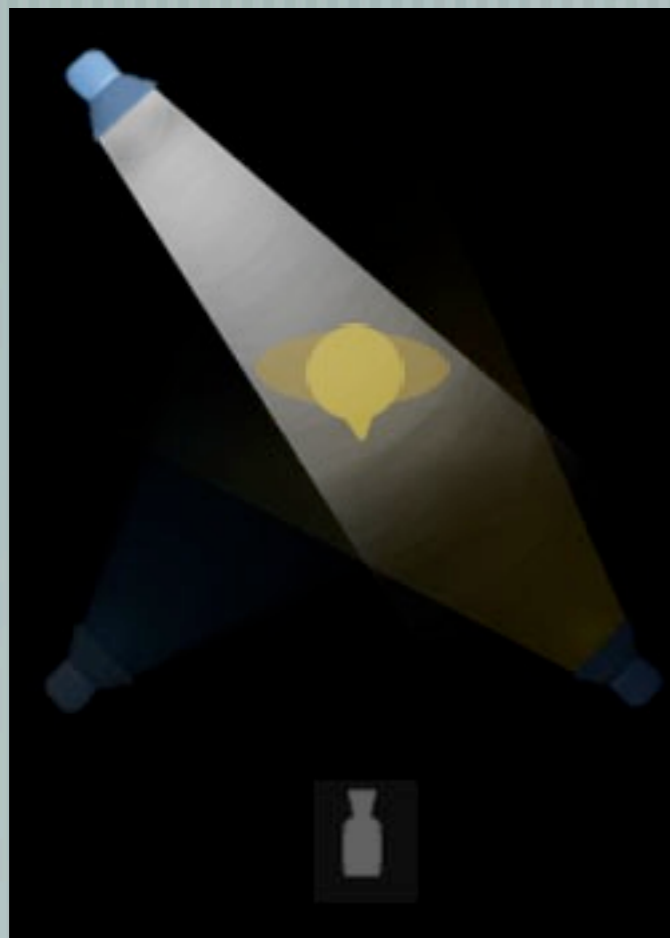

3 Point Lighting

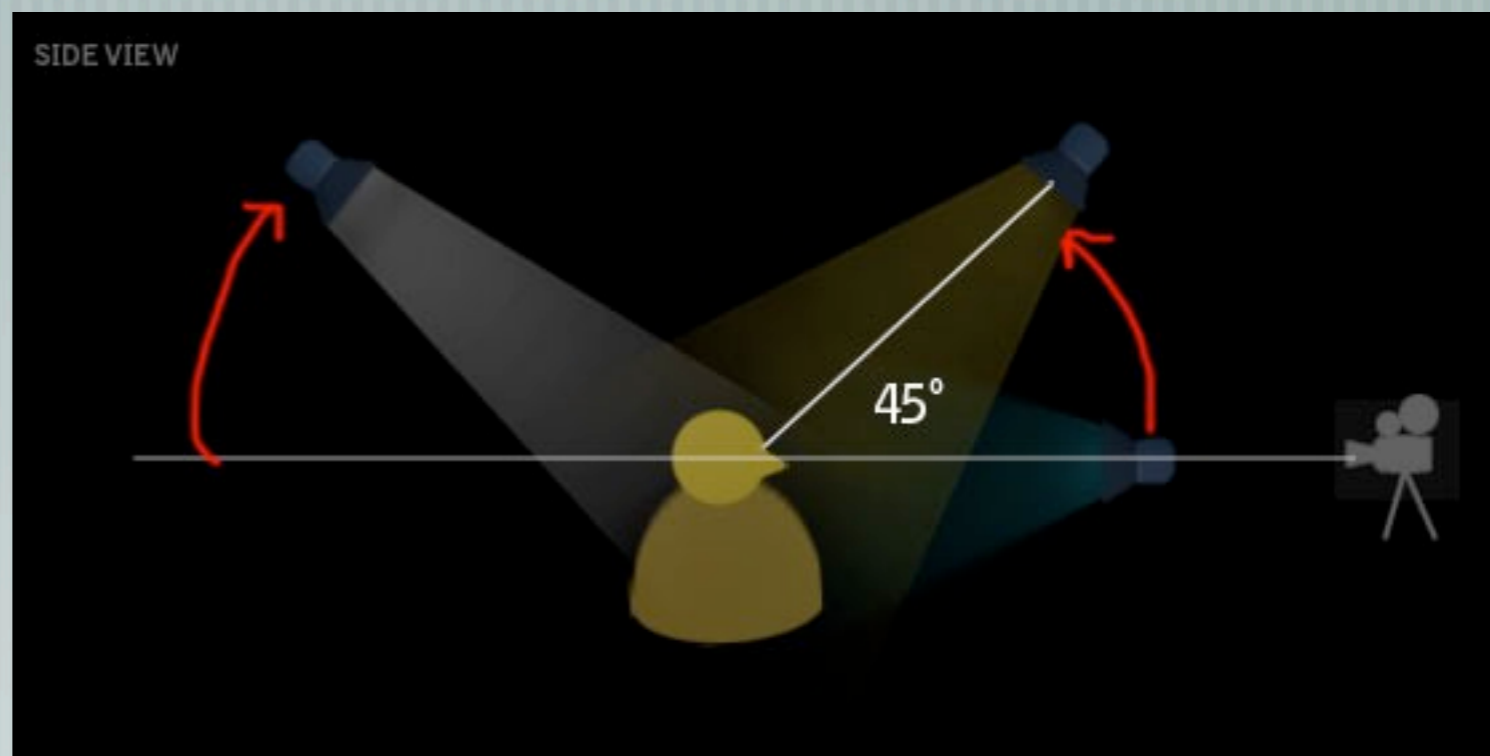
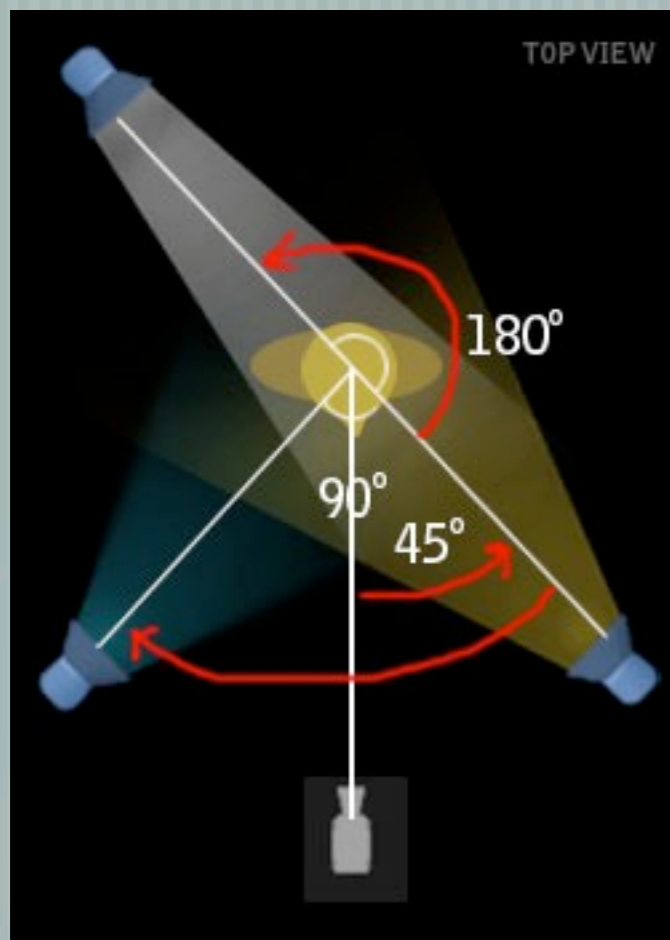

Examples

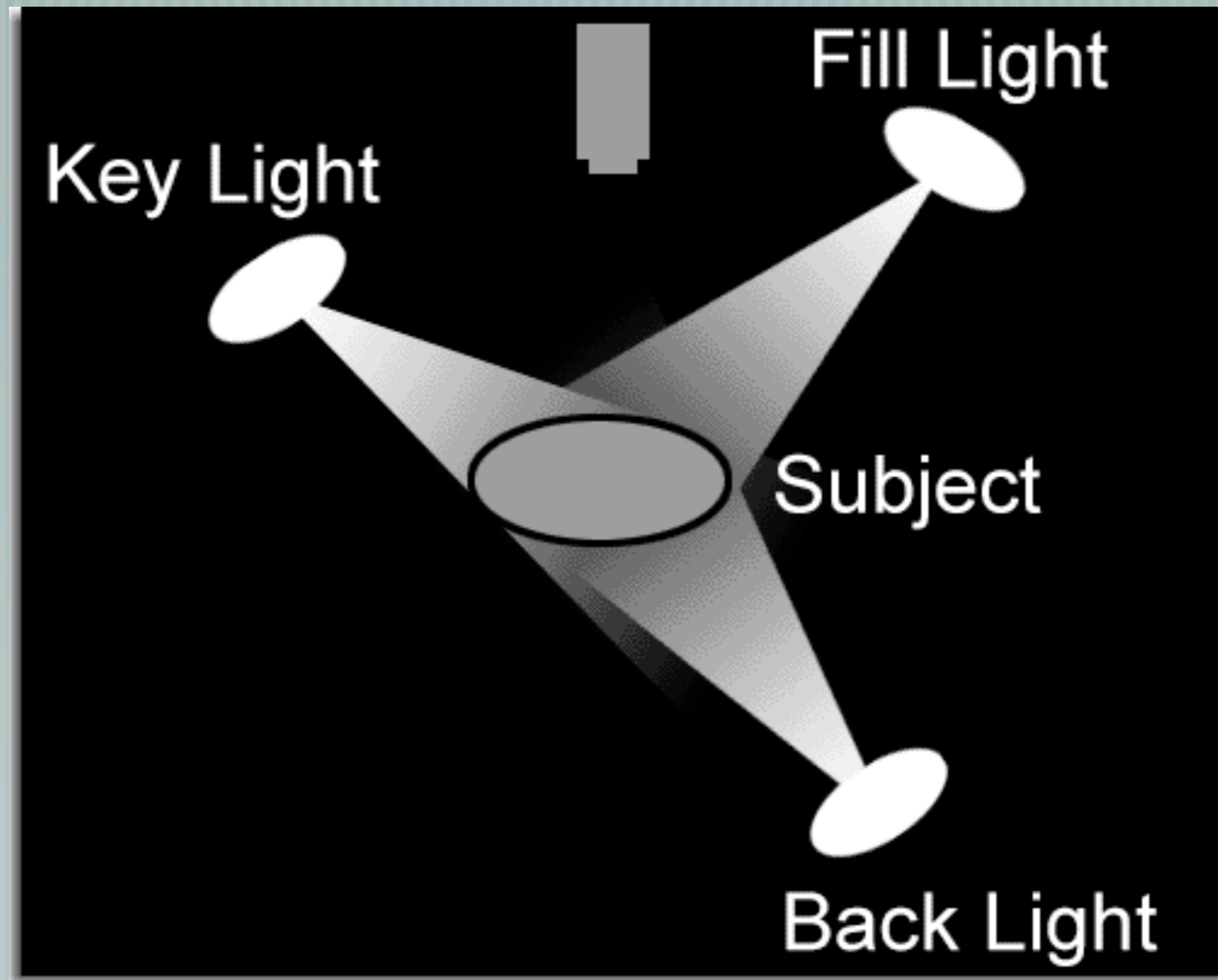

Existing Light

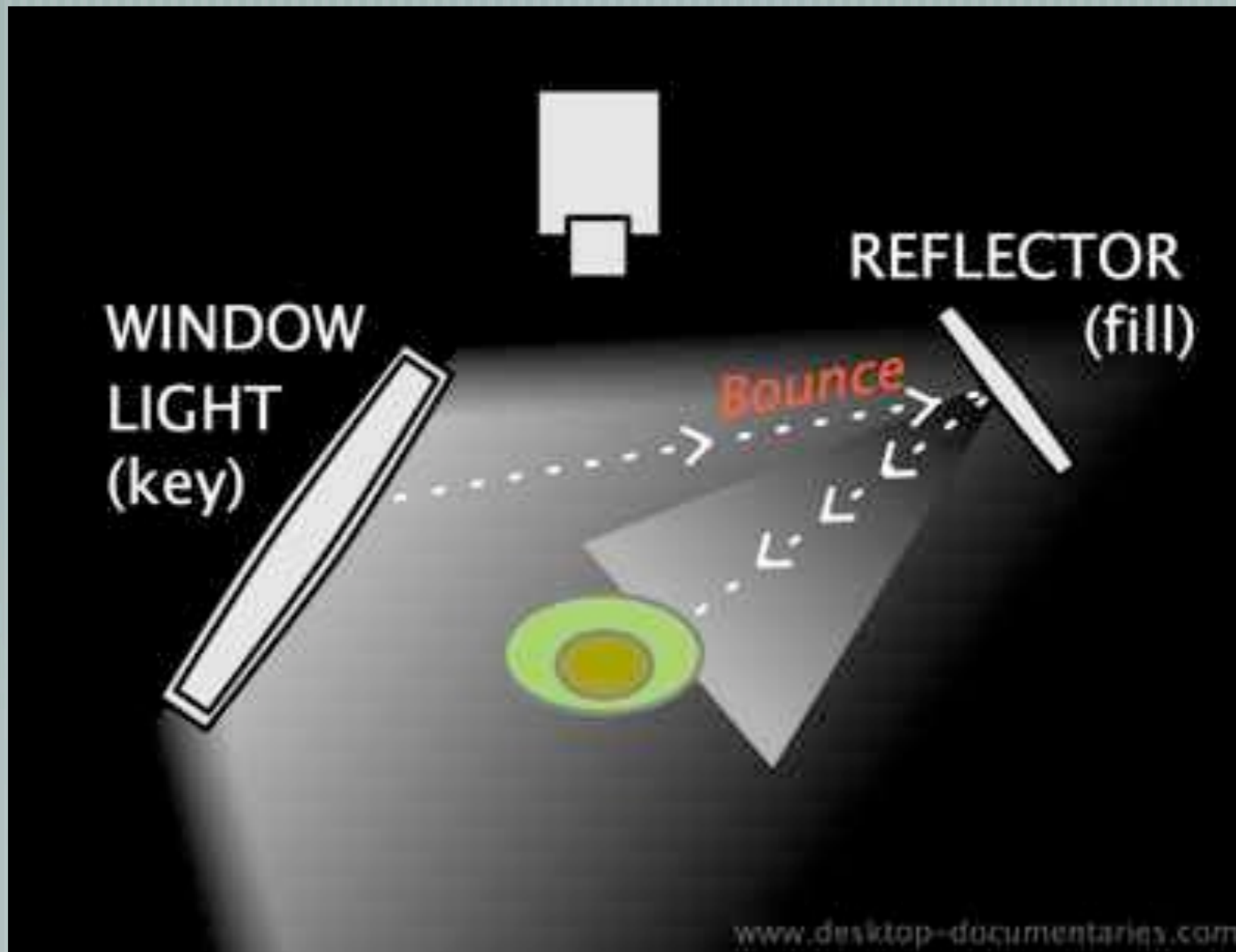

Where is the Main Light?

Where is the Main Light?



Where is the Main Light?

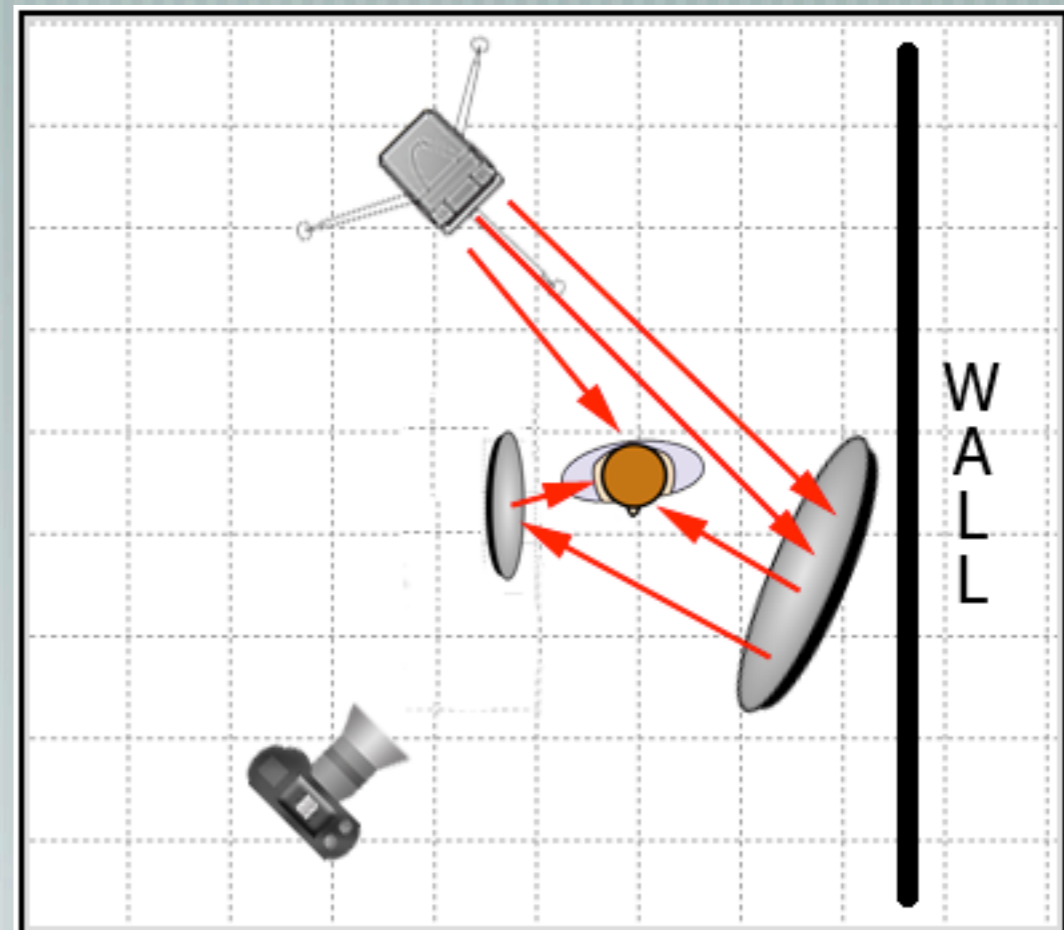

Where is the Main Light?

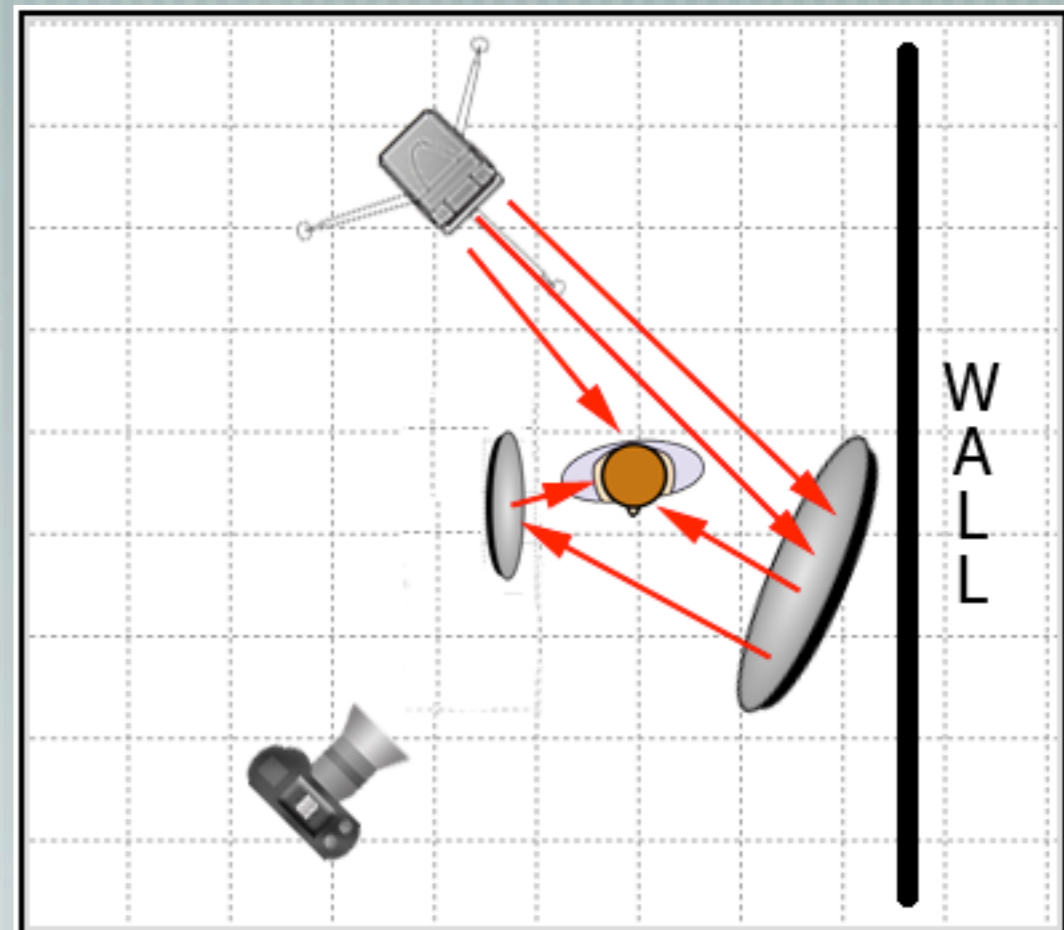

Where is the Main Light?

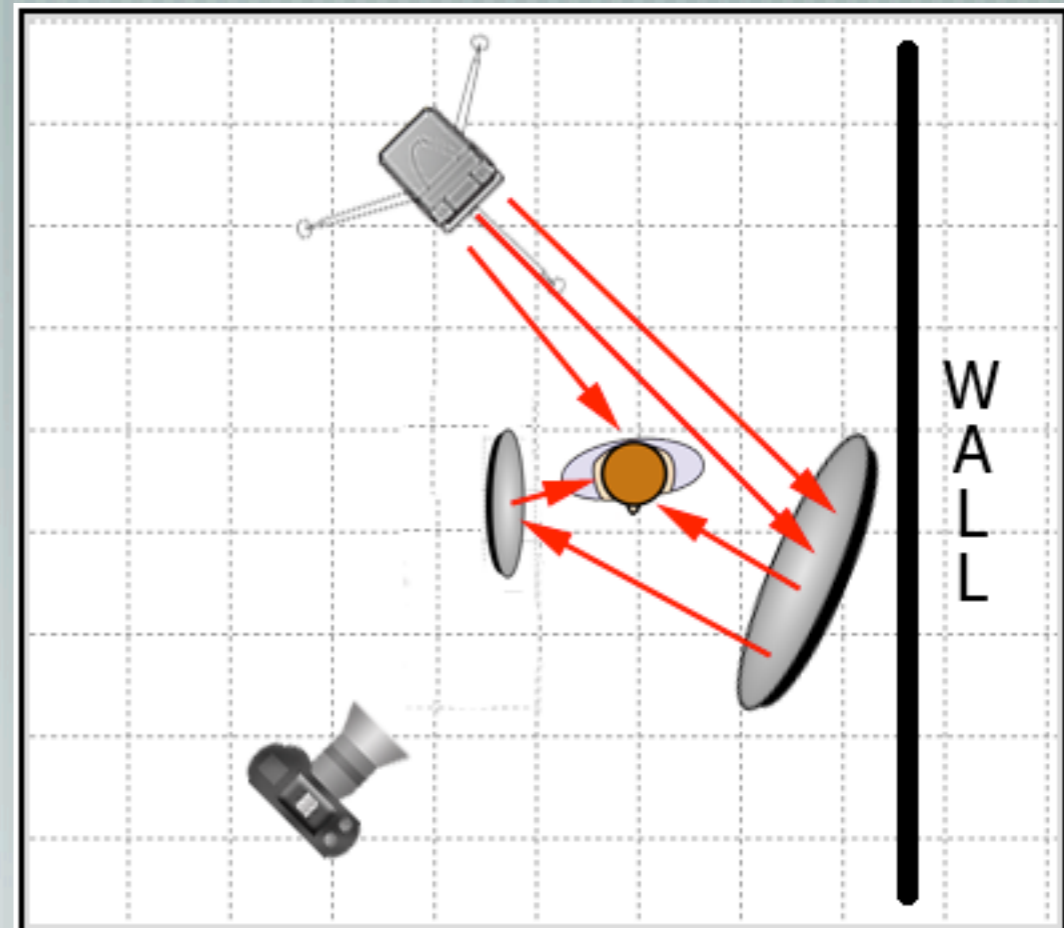

Where is the Main Light?

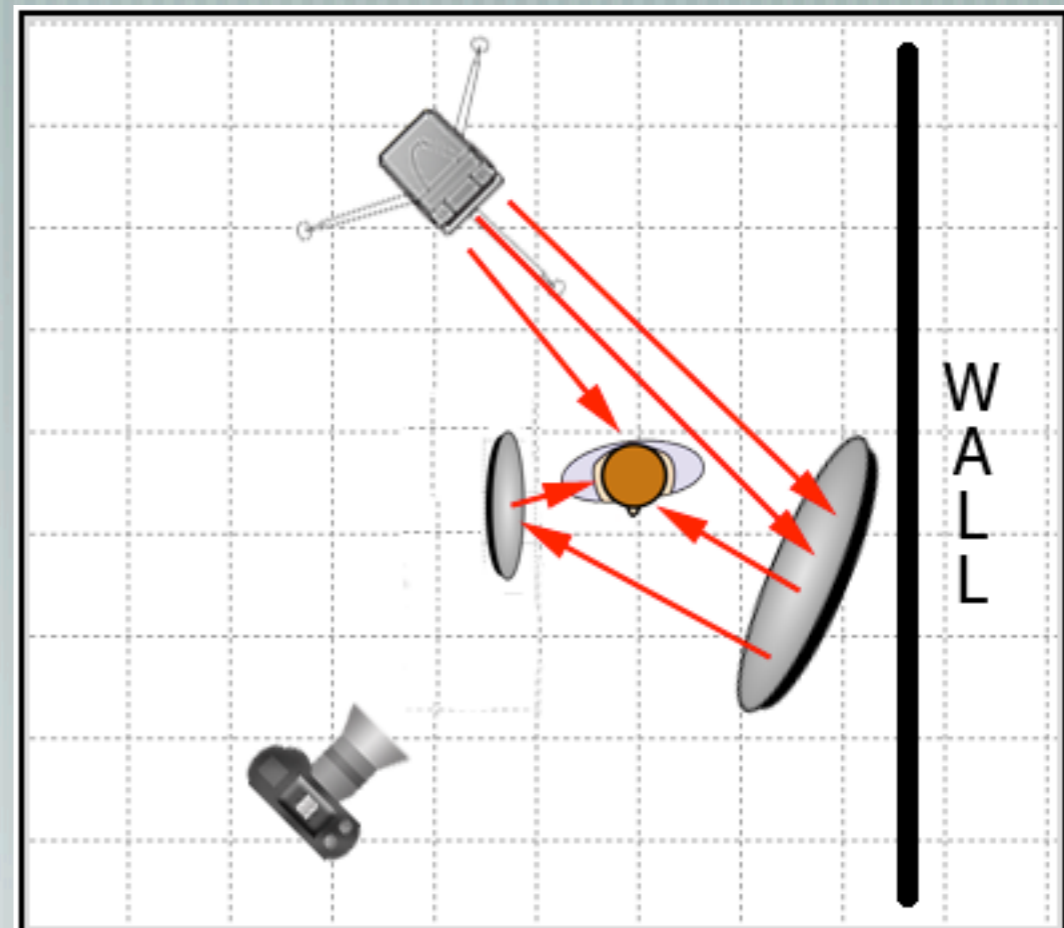

4th Point

- [Light the background

- [Not brighter than subject

- [Add interest

- Mood

- Context

- Use cookies/gels

4 Point Lighting

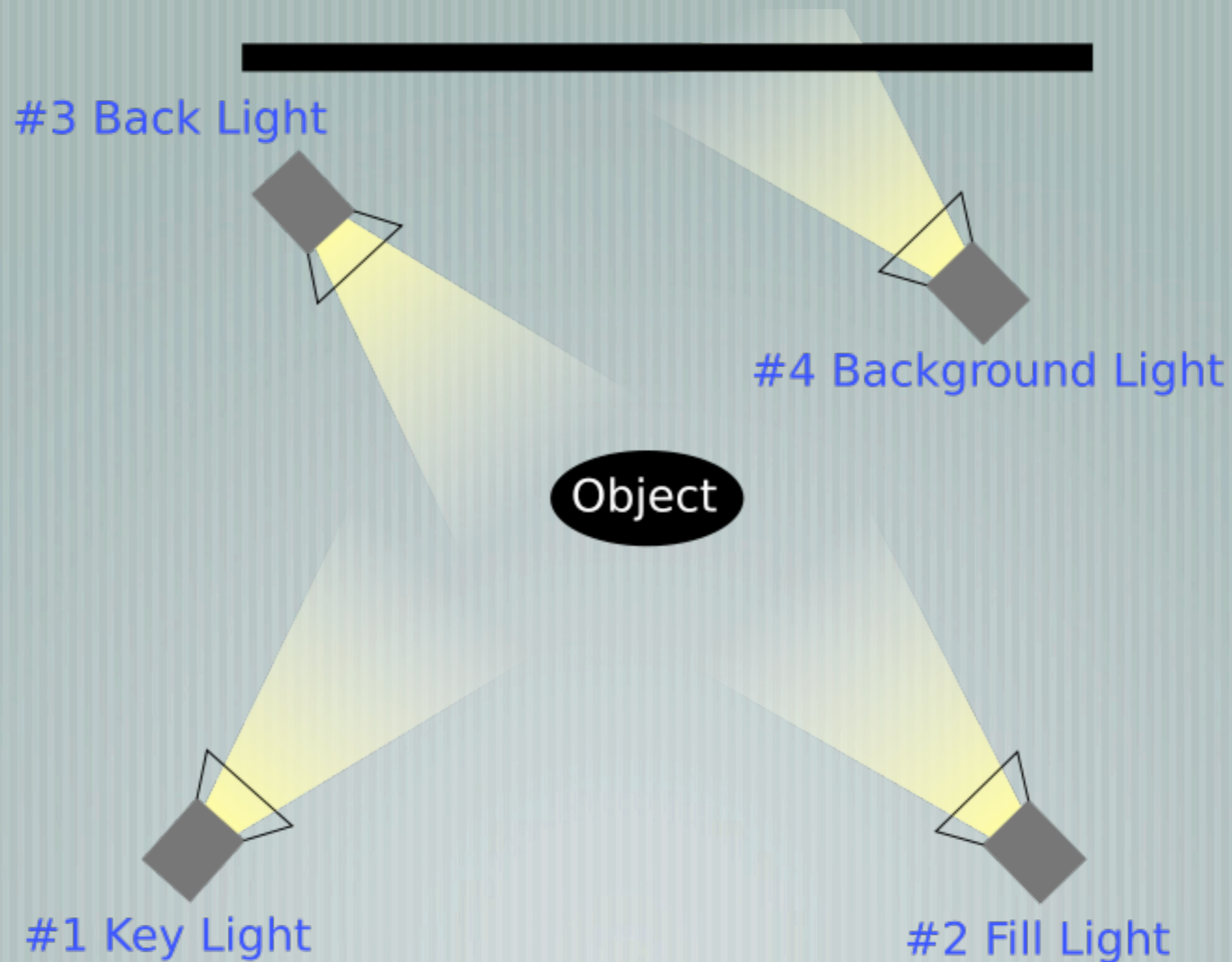

Example

Example



Example

